

# Brass and stainless steel rotary vane pumps CO/MO 30-200 series

The Compact and Compact Plus series rotary vane pumps are the smallest series of the Rotoflow® line of positive displacement pumps. Capable of high performances despite the small size, the Compact and Compact Plus series is the choice when space is an issue.

### Technical features and manufacturing characteristics

The Compact series housing as well as the Compact Plus series which is equipped with ball bearings supporting the rotor, are available in brass or stainless steel AISI 303. Both are assembled with a stainless steel AISI 303 rotor, carbon graphite pumping chamber and NBR seals. The inlet and outlet ports are 3/8" GAS or NPT threaded. The pumps can be connected to direct coupling motors with a stainless steel clamp. Maximum operative temperature: 70 °C (158 F).

### Available upon request:

- Viton®/EPDM seals
- Built-in relief valve
- California AB 1953 compliant brass



### MAIN APPLICATIONS

- Espresso coffee machines
- Beverage vending machines
- Post mix drink dispensers
- Water treatment
- Water dispenser
- Cooling systems



### TECHNICAL INFORMATION

Pump housing material	Brass or stainless steel	Max static pressure	20 bar/290 psi
Pumping chamber	Carbon graphite	Pump weight	CO 850 g (1.9 lb)
Ports	3/8" GAS or NPT		MO 1 Kg (2.2 lb)
Speed limit	1725 rpm		

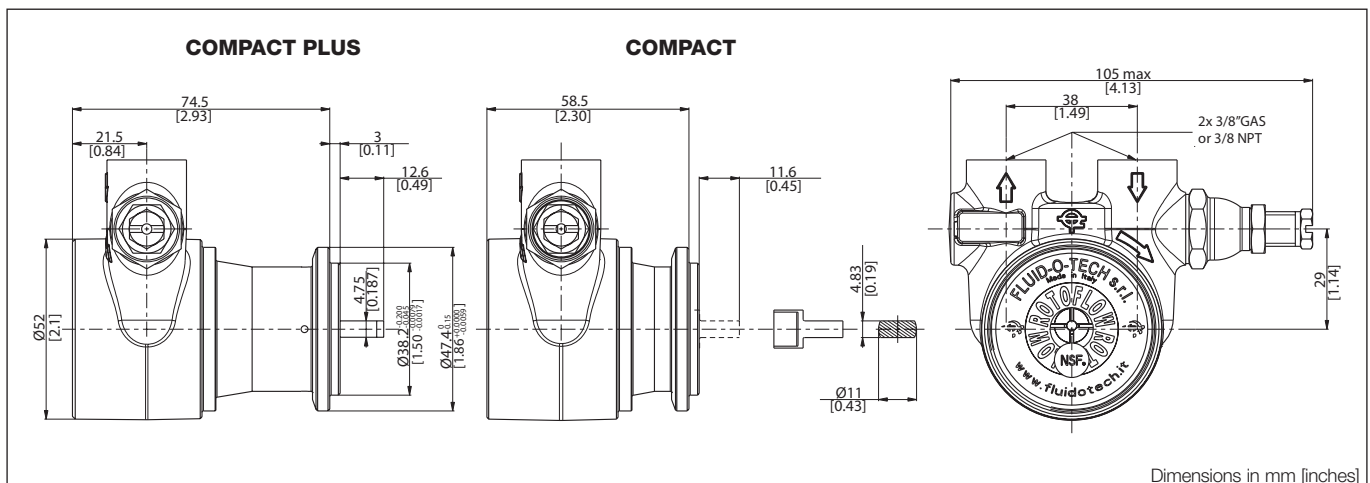

Dimensions in mm [inches]

# Brass and stainless steel rotary vane pumps CO/MO 30-200 series

Model CO/CA/CW (Compact)	030 031 034	050 051 054	070 071 074	100 101 104	150 151 154	200 201 204
Figure	A-A (50 Hz); A'-A' (60 Hz)	B-B (50 Hz); B'-B' (60 Hz)	C-C (50 Hz); C'-C' (60 Hz)	D-D (50 Hz); D'-D' (60 Hz)	E-E (50 Hz); E'-E' (60 Hz)	F-F (50 Hz); F'-F' (60 Hz)
Relief valve	NO STD BAL	NO STD BAL	NO STD BAL	NO STD BAL	NO STD BAL	NO STD BAL

Model MO/MA/MW (Compact Plus)	030 031 034	050 051 054	070 071 074	100 101 104	150 151 154	200 201 204
Figure	A-A (50 Hz); A'-A' (60 Hz)	B-B (50 Hz); B'-B' (60 Hz)	C-C (50 Hz); C'-C' (60 Hz)	D-D (50 Hz); D'-D' (60 Hz)	E-E (50 Hz); E'-E' (60 Hz)	F-F (50 Hz); F'-F' (60 Hz)
Relief valve	NO STD BAL	NO STD BAL	NO STD BAL	NO STD BAL	NO STD BAL	NO STD BAL

